

VALUE AND RELIABILITY.

MERITOR RED BRAKE CHAMBERS (SERVICE ONLY)



Meritor

**FOR
A WORLD
THAT'S
ALWAYS ON™**



MERITOR RED BRAKE CHAMBERS

For over 100 years Cummins-Meritor has been a leader in axle and braking systems for heavy vehicles. Meritor Red is an extended range of aftermarket braking components brought to you by one of the industry's most trusted names. Our new Brake Chambers are the latest addition to the line-up that delivers confidence and reliability you can count on.

FEATURES AND BENEFITS

Features	Benefits
<ul style="list-style-type: none"> Corrosion protected air spring Powder coated steel end cap 	<ul style="list-style-type: none"> Enhances performance with protection for parts providing better durability and longevity with use
<ul style="list-style-type: none"> Grade 10.9 high strength mounting studs 	<ul style="list-style-type: none"> Strength and superior durability
<ul style="list-style-type: none"> Side and back air ports 	<ul style="list-style-type: none"> Accommodates multiple mounting configurations
<ul style="list-style-type: none"> Premium Diaphragm 	<ul style="list-style-type: none"> Longer life for lower total operating cost
<ul style="list-style-type: none"> Double guided spring positioning seat 	<ul style="list-style-type: none"> Ensures reliable brake operation in demanding applications.
<ul style="list-style-type: none"> Anti-touch spring design 	<ul style="list-style-type: none"> Prevents spring wear and reduces risk of failure
<ul style="list-style-type: none"> 1 year on highway warranty 	<ul style="list-style-type: none"> Certainty for maintenance planning

SPECIFICATIONS

Part No.	Specifications	Brake Chamber
MBC20	Size 20, 2.25" stroke SAE J1469 & J2318 compliant Standard Service ports in two positions (3/8-18 NPTF) & distance between mounting studs (4.75")	
MBC24	Size 24, 2.25" stroke SAE J1469 & J2318 compliant Standard Service ports in two positions (3/8-18 NPTF) & distance between mounting studs (4.75")	
MBC30	Size 30, 2.25" stroke SAE J1469 & J2318 compliant Standard Service ports in two positions (3/8-18 NPTF) & distance between mounting studs (4.75")	



BRAKE CHAMBER DIAGRAM

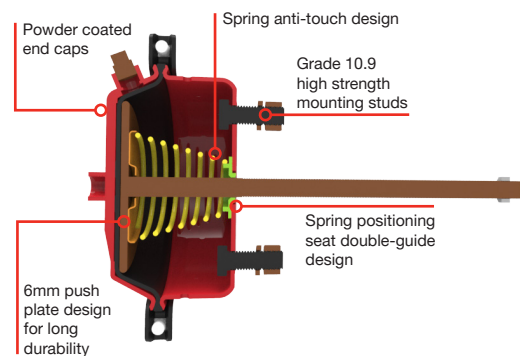

MBC = Meritor Brake Chamber



Meritor Heavy Vehicle Systems Australia
50 Calarco Drive
Derrimut, VIC 3026
AUSTRALIA

(03) 8353 6050

meritorpartsonline.com

CMFL086 - BRAKE CHAMBERS
(SERVICE ONLY) 08/23
Produced in AUS 08/23
©2023 Cummins Inc.